

PRODUCTION OF ELECTRICITY FROM RENEWABLE ENERGY SOURCES FOR HOME APPLIANCES AND NANO-GRID

Md. Emdadul Hoque¹, Arindam Biswas^{2,*}, Fazlur Rashid³, Ashfaq Mohammad Saad⁴
and Pronay Kumar Bir⁵

^{1,3,4,5}Dept. of Mechanical Engineering, Rajshahi University of Engineering & Technology, Bangladesh
²Dept. of Electrical & Electronic Engineering, Rajshahi University of Engineering & Technology, Bangladesh
¹emdadulhoque@gmail.com, ^{2,*}arindam.eee10@gmail.com. ³frashed10@gmail.com.
⁴ashfaqmohammadsaad10@gmail.com. ⁵pronaybir@gmail.com. Bangladesh

Abstract- This paper emphasizes on innovative ways of using power through everyday activities at home. A green approach uses ambient energy sources such as solar, biogas, hydropower and active/passive human power to generate electricity for home appliances. In Bangladesh demand of energy is increasing day by day but resources are limited. Maximum cases this energy produced from fossil fuel. Product of combustion of fossil fuel are irreversible. Consequently they are causing harmful effect in the environment causing greenhouse effect and various human health problems. To solve the problem best policy is to use renewable energy. This paper discuss on Nano-grid system energy production. If produced energy is higher than required then additional energy will stored in battery which can be used in night purposes. If production is less than requirement then shortage energy will be taken from grid supply. This paper also emphasizing on how produced energy can be converted into Alternative Current (AC) without storage.

Keywords: Process layout & sources of energy, Microcontroller readable data, Current to voltage conversion, Process algorithm.

1. INTRODUCTION

As a result of greenhouse effects and the global energy crisis, discovering sources of clean, renewable energy and developing daily life applications have become critical task. The intent of this study is the development of a self-sufficient house emphasizing the use of modern green energy technology to decrease environmental load, accomplish energy self-sufficiency and use energy wisely in order to build a sustainable, comfortable living atmosphere.

Due to contain high percentage of carbon in fossil fuel & there limitation in earth use of renewable energy increases day by day [1]. Renewable energy resources can be utilized in forms of radiant solar, wind, hydropower, biomass, geothermal, mechanical, and other potential sources. These energy sources provide many advantages to solving a majority of our energy problems. Some European governments offer incentives to solve environmental problems by reducing the use of conventional fossil fuel that causes greenhouse gases. [2] Renewable energy is derived from natural

processes that are replenished constantly.

In 2012, about 18% of global energy consumption came from renewables.

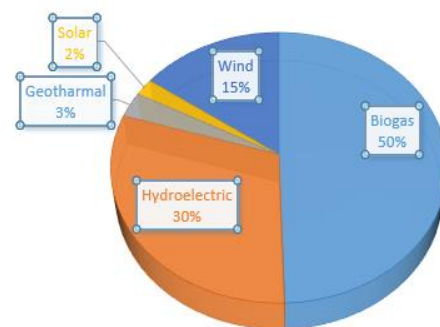

Fig.1: Energy extraction from Renewables.[3]

Abilities of renewables off grid or mini off grid homes are getting popular day by day. In those houses electrical

power generates on-site with sources such as solar, wind, micro hydro. With a generator or Micro combined heat and power with adequate fuel reserves.

2. PROCESS LAYOUT & SOURCES

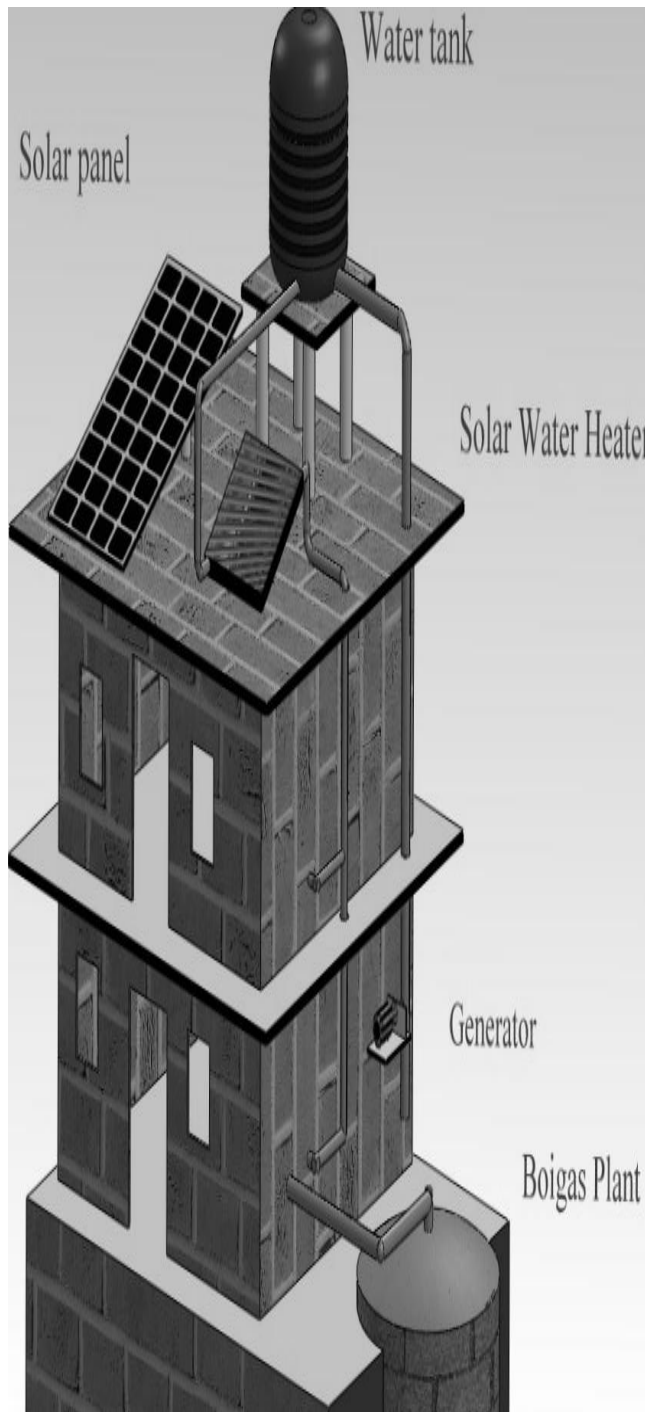

Fig 2: Potential renewable energy sources for self-powered house design [2]

2.1 Solar energy:

Solar photovoltaic (pv) modules generate electricity from sunlight, which can be fed into the mains electricity supply of a building or sold to the public electricity grid. The solar panel contains 4 cells, and each of them can

produce 0.45 volts and 100 milliamps, or 45 milliwatts. [4] Each cell measures 2 inches by 0.5 inches. In other words, with these solar cells can generate 45 mill watts in one square inch (6.45 square cm).

2.2 Biogas:

Biomass that is high in moisture content, such as animal manure and food-processing wastes. Biogas typically contains between 40 and 60 percent methane [5]. This high methane content makes biogas an excellent source of renewable energy to replace natural gas and other fossil fuels. The calorific value of biogas is appreciably high (around 4700 kcal or 20 MJ at around 55% methane content). [6] Biogas is typically used in factory boilers and in engine generate or sets to produce electricity and heat. If internal combustion engines are fuelled with biogas to produce electricity.

2.3 Water supply system:

Most of the family used motor to store water in tank or reservoir from ground. Water passes through the pipe at a certain velocity. By using a water turbine at the opening of pipe in the tank, easily can extract energy & electricity can be produced.

2.4 Solar water heater:

Solar water heating (SWH) is the conversion of sunlight into renewable energy for water heating using a solar thermal collector [7] SWH system the storage tank is horizontally mounted immediately above the solar collectors on the roof.

3. CONTROLLER & PROCESS ALGORITHM

Store of energy in battery or other storing device causes, loss of large amount of energy. This Controller will save the energy loss. Controller converts all the DC energy that produced in different sources into AC. At the same time of conversion it also control the fluctuation between demand & production. Remaining portion of energy requirement in house will be taken from grid. If required energy can be produced by renewable then grid will be untouched.

Instead of connecting the solar panel/grid to the load which is inconvenient in operating under the situation when sunlight is abnormal or absent here used a microcontroller and a power and priority base algorithm to divide the load among the grid and solar system. First the voltage of the solar panel is converted by an op-amp in 5V range and send this to the microcontroller. Then the loads are supplied for instance to measure the supplying current by Solar panel. A current transformer is used to convert the current to voltage and make it microcontroller readable. The current measurement is taken from the junction of 5K potentiometer. The algorithm in microcontroller calculate the power level of the solar panel. By comparing the instant power level and required power level for supplying all load the load is divided and connected part by part using relay switching to the main grid and solar panel. Thus huge amount of electricity is saved and the operation gore simultaneously.

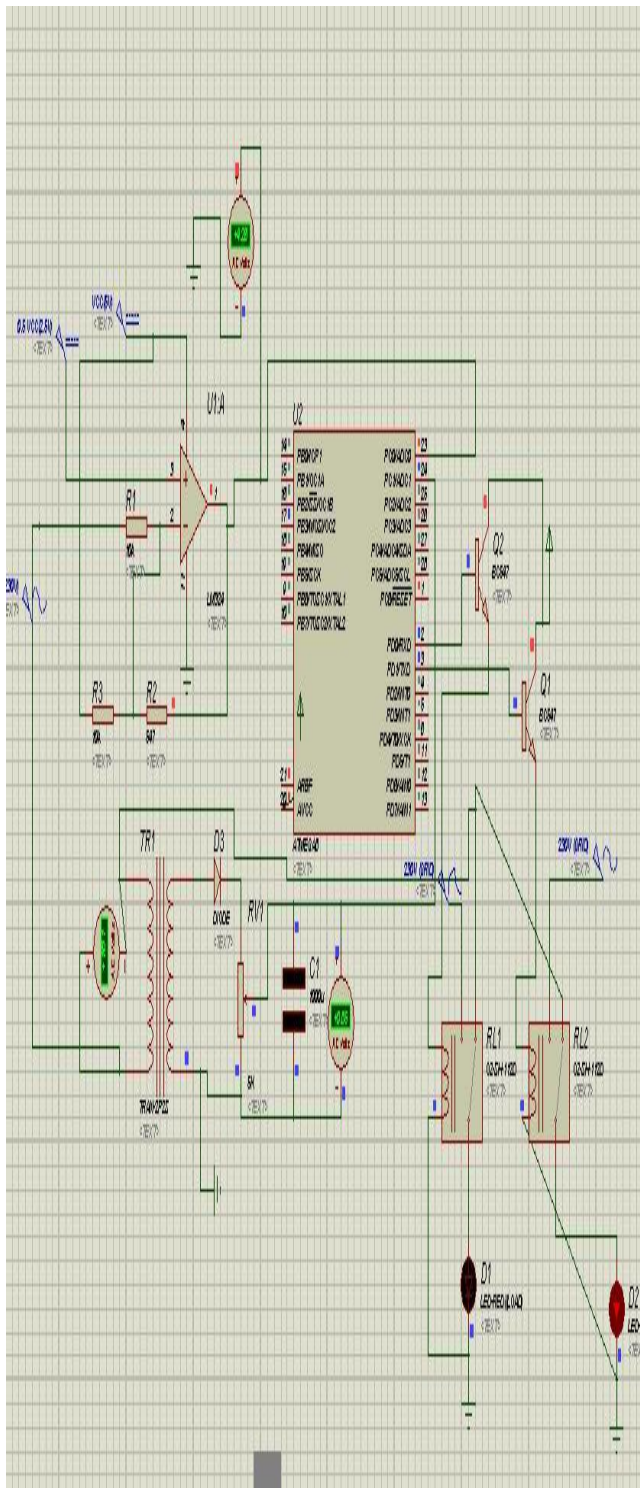

Fig.3.1: Micro controller simulation

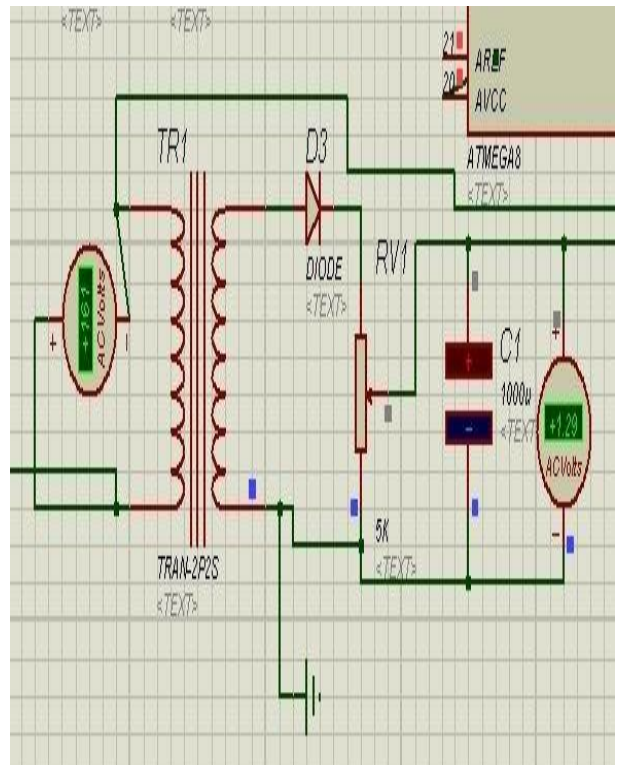

Fig.3.2: Current Converter Section for MCU input

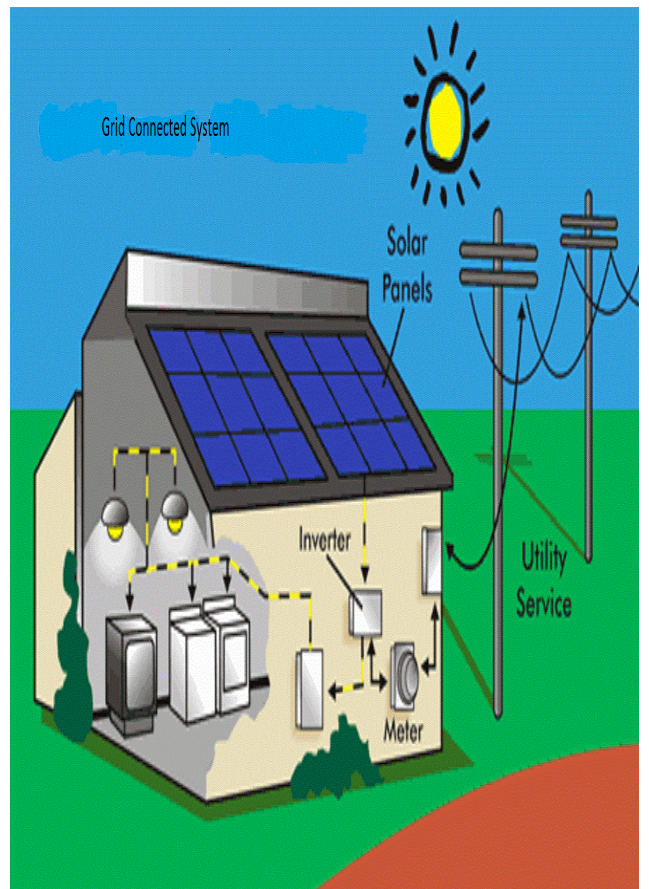

Fig.3.3: System outlook [8]

4. CALCULATIONS

Table 1: Required energy for home appliances which will be run 24 hour in a day [9]

Device	Number	Power, Watt	Total Power, KW
Light	4	30*4=120	
Ceiling Fan	3	50*3=150	
TV(25" color)	1	150	.914
Fridge	1 (16 cubic feet)	475	
Electric clock	3	3*3	

Table 2: Required energy for home appliances which will be run at a particular time in day [9]

Device	Number	Power, watt	Total Power, KW
Motor	1	1500	
Dryer	1	400	
Air conditioner	1	1000	3.2
Washing machine	1	300	

Maximum energy that can be required
 $0.914+3.2=4.314\text{KW}$

Table 3: Energy can be extracted from Renewable sources:

Source	Efficiency	Generated Power, watt	Total Power, KW
Solar (61"×41") 17.3 ft ² area [10]	80%	345*4=1380 (2 Panel)	
Solar water heater (light intensity 800w/m ² , pipe :length 12ft width 0.75 in)	21%	217.17*2=434.34	3.29
Bio-gas (13 kg waste 9800 KJ/Kg)	--	1474.25	

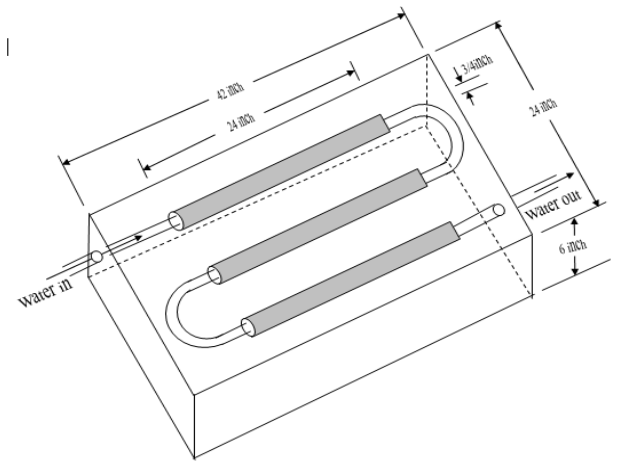

Fig. 4.1: Dimension of solar water heater (Efficiency 21%) [11]

Considering maximum energy production & requirement
 Shortage of energy $(4.314-3.29) = 1.024 \text{ KW}$

Here maximum required & production of energy for any particular time is taken into consideration. If produced energy is higher than required then additional energy is stored in battery which can be used in night purposes. If production is less than requirement then shortage energy will be taken from grid supply.

5. CONCLUSION

Effective ways of solar PV array Cascaded system for various consumption systems are important due to its low cost and simplicity. A new solar PV array Cascaded system was proposed and its control performances were investigated. This approach based on by using Controller. Controller converts all the DC energy that produced in different sources into AC. At the same time of conversion it also control the fluctuation. Remaining portion of energy requirement in house will be taken from grid. If required energy can be produced by renewable sources then grid will be untouched. So developed new system can maintain the required energy demand in remote house. It's a low cost system and contain conventional electrical and mechanical element like Controller. Due to this simple construction element its price will be very low and has increased its workability in working area which decrease the pressure of fossil fuel enormously.

6. ACKNOWLEDGEMENT

Authors express their enormous gratitude and heartiest gratefulness to Dr. Md. Emdadul Hoque, Professor, Department of Mechanical Engineering, Rajshahi University of Engineering & Technology, for his guidance, valuable suggestions and full time co-operation. Without him it won't be possible for the authors to overcome the difficulties of the project and complete it within the scheduled time.

7. REFERENCES

- [1] "Fossil Fuel Wikipedia"
Available at: https://en.wikipedia.org/wiki/Fossil_fuel
- [2] Dr. E. S. Karapidakis, Anna Tsave "Electric power production by biogas generation at volos landfill in Greece"
Available at:
http://www.researchgate.net/publication/228468235_Electric_power_production_by_biogas_generation_at_volos_landfill_in_Greece
- [3] "Renewable Energy scenario"
Available at :
http://www.google.com.bd/imgres?imgurl=http://sagaciousnewsnetwork.com/wp-content/uploads/2014/02/off-the-grid-d-d-565x475.jpg&imgrefurl=http://www.sagaciousnewsnetwork.com/court-rules-off-the-grid-living-is-illegal/&h=475&w=565&tbnid=r2ssDEP_dLK1KM:&zoom=1&docid=LzhCEFzsnLCsaM&ei=g_6kVfPaF9O2ogSSkaXgDg&tbnm=isch&ved=0CB8QMygAMABqFQoTCLooweTN2sYCFVObiAodkkgJ7A
- [4] S. C. Banik, C. D. Pathiranage, K. Watanabe, and K. Izumi, "Behavior generation through interaction in an emotionally intelligent robotic system", in Proc. of the IEEE Intl. Conference on Industrial and Information System, Peradeniya, Sri Lanka, Aug 9-11, 2007, pp. 517-522.
- [5] "Biogas Wikipedia"
Available at:
<https://en.wikipedia.org/wiki/Biogas>
- [6] Ravi P. Agrahari1, G. N. Tiwari2 "The Production of Biogas Using Kitchen Waste"
Available at:
<https://www.google.com.bd/url?sa=t&rct=j&q=&esrc=s&source=web&cd=1&cad=rja&uact=8&ved=0CCIQFjAAahUKEwj19bT-5dzGAhUBlogKHfSHCY8&url=http%3A%2F%2Fwww.ijesci.org%2FDownload.aspx%3FD%3D10163&ei=UySmVaWAJ4GsogT0j6b4CA&usg=AFQjCNEBu4smKe69iA9Dj8SHap20zLLZqg&bvm=bv.97949915,d.cGU>
- [7] "Solar Water Heater Wikipedia"
Available at:
https://en.wikipedia.org/wiki/Solar_water_heating
- [8] "Grid Power Home"
Available at:
https://www.google.com.bd/search?q=grid+power&espv=2&biw=1242&bih=585&source=lnms&tbnm=isch&sa=X&ved=0CAYQ_AUoAWoVChMlrZ3M8-jcxgIVhVmICh0CKQiK#tbnm=isch&q=grid+power+home&imgsrc=QcuF7xhhkkNPBM%3A
- [9] "Home appliance power consumption"
Available at:
<http://www.absak.com/library/power-consumption-table>
- [10] "Solar panel"
Available at:
<http://www.lightsonsolar.com/solar-basics-kw-and-kwh/>
- [11] Nur-E-Fatima Naima Akhter "Design, construction & performance test of a solar water heater" undergraduate thesis in Rajshahi University of Engineering & Technology